

Engine mounts: Lord J-7402 series or equivalent
 Propeller Flange: ARP-502 and SAE-1
 Weight: 120kg (Engine inc starter and alternator: oil & cooling systems dry)
 Propeller Governor mount: AND-20010
 Details subject to change without notice

Issue "A" Date 10-Jun-02		Wilksch Airmotive
Scale: Do not scale	© COPYRIGHT 2001	
Drawn By: M Long	WWW.WILKSCH.COM Phone:- 0870 1709670 Facsimile:- 0870 1709678 Email:- sales@wilksch.com	
No: 655	Sheet 1 of 1	DIMENSIONS IN MM UNLESS OTHERWISE STATED 3RD ANGLE PROJECTION
Title: 4 Cyl Production Engine Installation - WAM 160		

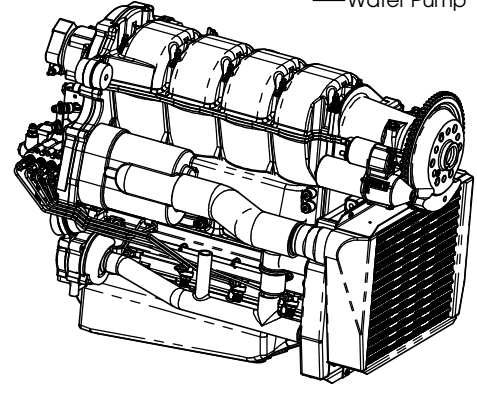

Issue "C" 5-April-05 MGL
 Pictorial changes only